



Analog-Intensive Mixed-Signal (AIMS) Solutions

Introduction

Today's consumer electronics products contain more analog-intensive components and demand an Analog-Intensive Mixed-Signal (AIMS) foundry solution for optimized chip design. AIMS technologies such as RF CMOS, SiGe BiCMOS and HV (High Voltage) CMOS make possible what were once formidable design challenges by providing integrated circuit technologies that allow analog components to be manufactured in cost effective specialty silicon platforms. These technologies enable consumer applications such as wireless personal area networks, portable GPS systems, and TV tuners in cell phones and PCs. Jazz Semiconductor addresses these market demands by offering modular AIMS technologies on a baseline RF CMOS process. Jazz is focused on initiatives to accelerate time-to-revenue for AIMS products and provide better price/performance and power consumption for specialty CMOS technologies.

AIMS components are located at the critical system interface in most wireless and optical communications networks. The focus of these designs is on the optimization and differentiation of analog performance. AIMS solutions facilitate this by providing technologies that are ideal for high-speed analog performance where needed, reserving advanced digital CMOS technologies for high density digital components. This "Best of Breed" analog system design and partitioning is often found in System-in-Package (SiP) or Multi-Chip Modules (MCM).

AIMS markets

AIMS markets include a growing number of communications systems as new devices and protocols emerge. Advances in specialty Si technologies have increased the integration and proliferation of AIMS products in wireless consumer applications. Soon, every TV, PC, digital camera, cell phone and MP3 player will have wireless connectivity provided by AIMS products and technologies.

Analog integration and system partitioning will likely continue to stimulate the expansion of this market. This will result in an increased number of analog interfaces in each highly integrated product. These analog designs will evolve into more complex products with shorter product life cycles. Reduced development time, cost, size and power consumption will be required to meet these new market challenges for AIMS products.



AIMS Products

Specialty CMOS technologies have evolved into a platform that is ideal for analog-intensive mixed-signal products. These products include transceivers, tuners, oscillators and amplifiers operating at frequencies up to 10 GHz. All of these products take advantage of the analog performance and digital integration capabilities in standard CMOS. What makes these products so difficult to design in a standard digital CMOS technology is their common focus on analog performance.

AIMS products are found in the critical analog blocks of the communications system. It is in these products where analog performance is of paramount importance and digital integration is secondary. These blocks are typically the analog interface between the components in the digital world. Their analog performance often determines the system performance, size and power and can't be compensated for by digital processing.

Because of the importance of the analog performance in these products, the amount of digital integration is limited. These products do not typically include microprocessors or large memory blocks and thus do not require complex System-on-Chip (SoC) implementations. AIMS technologies allow the designer to produce optimum analog performance with some digital content. These products can be used in Best-of-Breed (BoB) system solutions, Systems-in-Package (SiP) solutions or Multi-Chip Modules (MCM) when complemented with digital chips produced in advanced digital CMOS technologies.

The cost and manufacturability of these technologies is critical to support widespread adoption of these AIMS products. The cost/performance trade-offs are optimized in these systems when analog-intensive products are built on AIMS technologies. SoC implementations of AIMS products waste a lot of die area and design time trying to fit the product into an advanced CMOS technology. In addition to the lower development cost, there is also a significant improvement in time-to-revenue when using these modular AIMS processes.

The choice of foundry has a significant impact on how AIMS products are designed and differentiated. Cookie cutter digital foundries provide state-of-the-art CMOS, but offer few benefits for analog performance. High performance AIMS designs require the innovation of specialty technologies that are typically customized, captive processes of Integrated Device Manufacturers (IDM) or research labs. Jazz combines the innovation offered by specialty processes in a high quality manufacturing foundry environment that enables successful AIMS products. Jazz is the recognized leader in the AIMS foundry landscape.

AIMS Foundry Landscape

Innovation

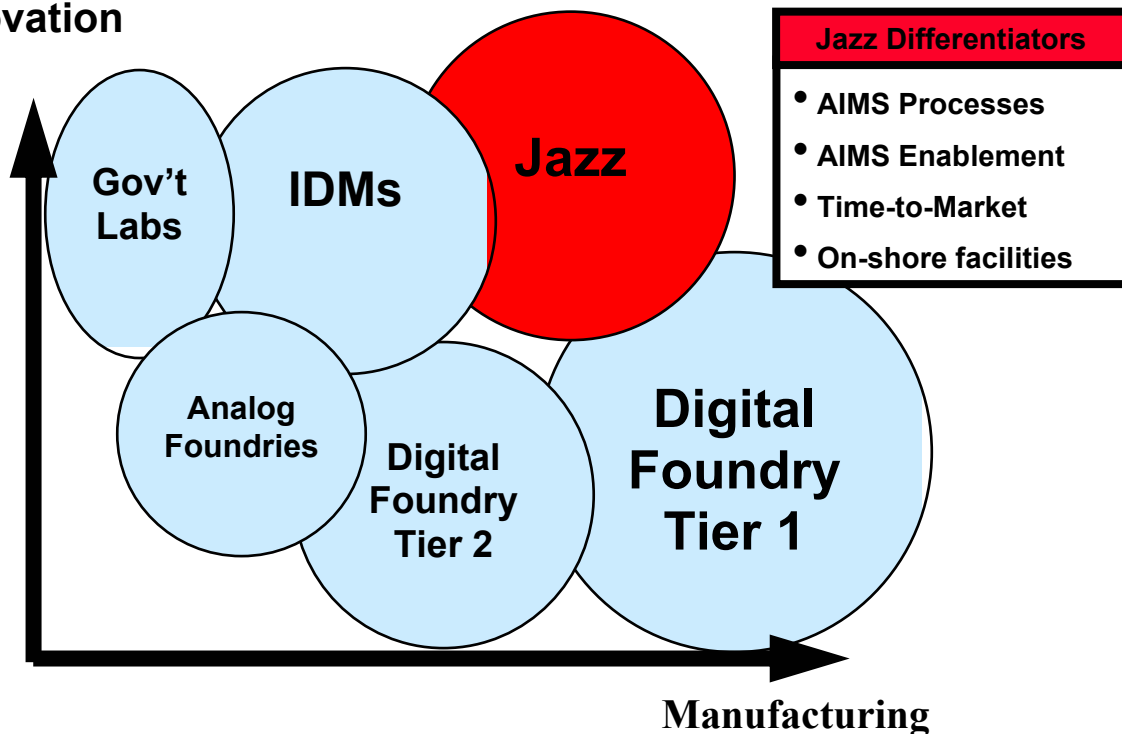

The Jazz AIMS initiative provides the fastest time to revenue by offering a combination of specialty CMOS technologies and the design enablement tools needed for first pass success. Success relies on both the Technology and Enablement elements to be seamlessly integrated into a design platform.



AIMS Technology Solutions

Jazz offers modular AIMS technology solutions designed to accelerate time-to-revenue of AIMS products by providing leading edge specialty CMOS IC process technologies and optimized design enablement technologies.

The AIMS process technologies are built on a baseline Si RF CMOS technology that extends from 0.5-um to 65 nm nodes. Jazz has developed an enhanced RF CMOS technology that includes advanced devices, models and tools and provides a low cost option for analog-intensive designs.

To provide even more performance for AIMS products, Jazz provides a modular technology platform of specialty technologies that includes BiCMOS, SiGe BiCMOS and DMOS. These technologies are built upon the enhanced RF CMOS and extend the performance with modules tailored for specific applications. Because they are modular processes, IP can be re-used or ported across several different products and technologies decreasing design time and increasing efficiency.

The breadth of these technology offerings allows designs to offer the most integration of analog content while maintaining superior analog performance. This approach allows the designer to optimize the price/performance and power consumption of AIMS products. These modules extend the capabilities of CMOS-based technologies to higher frequencies, lower noise, lower power and higher voltage.

Broad Specialty AIMS CMOS Technologies

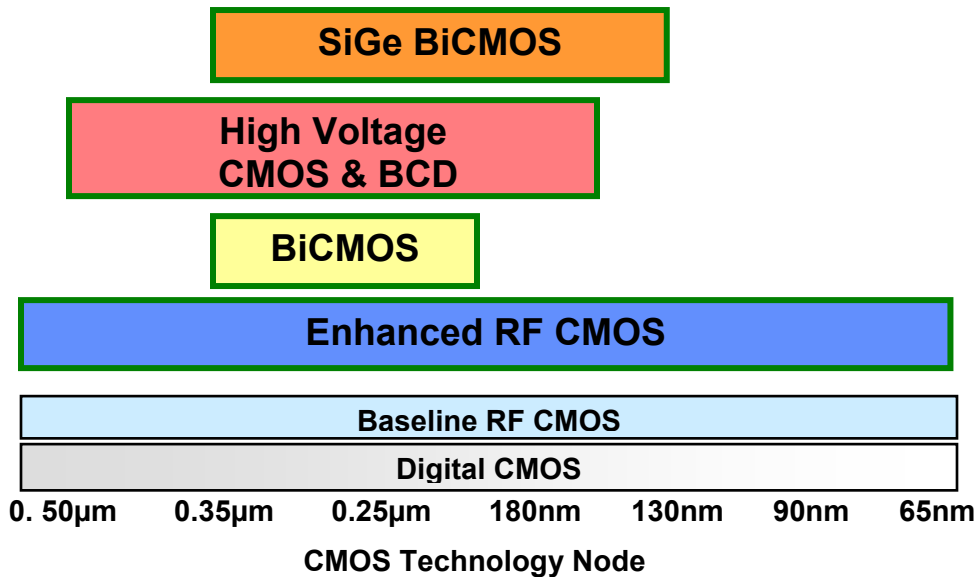

AIMS Enablement

The Jazz AIMS technology solution also includes a state-of-the-art design enablement suite of models and tools. The nature of advanced AIMS products demands solutions to complex circuit and system simulations. Typical CMOS models do not account for effects that are significant in analog-intensive designs which can degrade system performance. Jazz has pioneered advanced models and tools that provide a higher degree of simulation accuracy which leads to first pass design success and shorter design cycles. Because physical dimensions are also important in analog-intensive designs, Jazz provides layouts optimized for RF performance and incorporates advanced parasitic extraction capabilities into design tools.

Jazz has pioneered the implementation of advanced PSP CMOS models to improve the accuracy of analog designs. The traditional BSIM CMOS model works well for digital applications and simulations but its shortcomings are evident in analog-intensive designs, even at larger gate geometries. This, and other advanced device models, provides more accurate simulation and better design predictability and performance.

Another example of design enablement leadership is the Jazz Inductor Toolkit (JIT). The latest release, developed and supported by Jazz, includes an inductor optimizer for multiple configurations and includes models of the latest CMOS inductor technologies. This tool has proven to optimize design performance, reduce die size and shorten design cycles in analog-intensive products.

Jazz also takes AIMS design enablement one step further by developing tools specifically for manufacturing of AIMS products. One of the biggest concerns about analog-intensive designs is the performance vs. yield trade-off. AIMS product yields are typically a function of the analog performance requirements and power and size of the design. To better understand this trade-off, Jazz has developed tools that allow everything from simple analog yield estimates to complex statistical driven yield analysis. These tools can be used during the design phase as well as once the design is completed and the product is in high volume production. Models can be generated for production to help maintain high yields and manufacturability while the Jazz Process Control Model Tool (PCMT) closes the loop between circuit simulation and actual silicon results.

Summary

Jazz Semiconductor is focused on providing foundry solutions to accelerate the time-to-revenue of AIMS products. As the number of AIMS products increases in today's connected consumer devices, analog designers need a foundry focused on providing low cost, high performance analog technology. Jazz Semiconductor provides new specialty technology options and new AIMS design enablement tools that will fuel the growth of the analog-intensive mixed-signal market.